

Old Paths

Stand ye in the ways, and see, and ask for the old paths, where is the good way, and walk therein, and ye shall find rest for your souls.
Jeremiah 6:16

The secret of the LORD is with them that fear Him; and He will show them His covenant.
Psalm 25:14

Vol. 8, No. 1

Straight and Narrow

January 1999

THE YEAR 2000 - Y2K - AND YOU

By Allen Stump

We are now less than twelve months away from the year 2000 A.D. Contrary to popular belief, the year 2000 is not the start of the next millennium. The next millennium will begin January 1, 2001. However, the date January 1, 2000 is considered an important date and many are expecting something climactic to happen then even if they do not know what it is.

Many religious leaders and organizations are looking for the world's conversion and a millennium of peace to begin. The Pope and several evangelical Protestants are working towards a unified position and witness to present to the world. Anyone who is out of step will not be considered Christian because they are not willing to see the prayer of Christ as recorded in John 17 answered.

The most common thought among the people of the world regarding the year 2000 is what is known as the "Y2K" problem. Only those in a time warp have not heard about it. Y2K stands for the "year 2000." It involves the possible shutdown of computers that were programmed with only a two-digit year dating system instead of a four digit dating system.

The troubles that could be associated with the Y2K problem have been discussed quite a bit for the last few years. Since almost everything is computer driven and controlled today, if the computers come to a standstill, society will also. As someone said, "It would be like going back to the horse and buggy days without the horse and buggy!"

While banking and communications were the early targets of concern, the biggest fear today centers around the electric power plants. If they shut down

everything else shuts down including computer-controlled systems that are Y2K compliant.

Computer "experts" seem divided on how many and what types of systems will be ready by the end of the year, but all seem to expect some problems. A few believe that the main "bugs" will be worked out by then; some believe that total chaos will occur at the stroke of midnight! How should we approach the problem?

If I were to tell you that there would be no problems with Y2K and you made no preparations and then chaos occurred, I would be, to a degree, responsible for your situation. I could take the view that total shutdown will occur. If the system fails then, I would look like a prophet. If total shutdown did not occur I could say that God in His mercy gave us more time and at least you were not hurt by being ready. The truth is that while I have my ideas about Y2K, I do not claim to be an authority or have the answers.

Some have said that there are too many of the "Big Boys" who wish for normal life to prosper and continue when the year 2000 comes to let things crash. Perhaps this is so. I do know that the technical answers to the problem exist. Implementation may not

Also in this issue:

- Let God be True - Etim Udo Akor p. 3
- Three Days - Pat Kroeger. p. 6
- Youth's Corner p. 11
- Hearth to Hearth - Editor p. 12
- A Stirring Testimony - Grace Cox p.12

be as easy. One of the first places the Y2K bug showed up was in using credit cards that had expiration dates in the year 2000. Interestingly it did not take the banks very long to clear up this problem. Money still talks! Although at last report few if any banks were totally Y2K compliant, they *claim* they are working on it and plan to be ready by year's end.

For years we have been counseled to get out of the cities and into the country to live. If we do not get out of the cities now we may not be able to later. Many who live in metropolitan areas and rely on public transportation could not leave in the event of a power outage. Some have automobiles but you cannot drive your car without gasoline. Gasoline cannot be pumped and sold without electricity.

If the power plants shut down, then everything else shuts down.

For those in the country there would be three main necessities: water, food, and shelter. The biggest concern would be fresh water. Those who depend on city water supplies or for electricity to pump water from wells will be without water if the electric power fails. Springs or wells that could be hand drawn can supply water. Food would be the next biggest concern. Personally, I plan on the biggest garden I have ever planted this year. Food should be canned or dried but not put up in freezers for obvious reasons. Shelter that is dry and, where climate necessitates, warm is important. Wood-burning stoves may work well to produce heat for some, but remember, chain saws use gasoline. Getting the wood in early and having several tanks of fuel on hand would be important. Other heat sources could be coal or liquid propane as well as solar heat and power.

There is a certain amount of preparation that needs to be made even if the Y2K bug is fixed. As we noted earlier, we have been counseled to leave the cities long ago. According to prophecy there is coming a time of trouble in this world, both physically and spiritually, such as has never been seen. Some have suggested that the powers that be will use Y2K to start a national emergency and declare marshal law starting the final movements of earth's history. With the current track record of President Clinton combined with his upcoming Senate trial and the problems with Iraq, this is not a "far fetched idea."

One thing we can know for sure, if it is time for history to close, nothing will stop its onward march. The signs tell us that we are near the coming of Jesus in the clouds of heaven. If the year 2000 is not the end it is certainly the beginning of the end. The question that should haunt us is: "Are we making the preparation necessary for the end times?" Proverbs 22:3 says, "A prudent man foreseeth the evil, and hideth himself: but the simple pass on, and are punished."

While there are physical preparations that all Christians should be making for either Y2K or the time of trouble, the most important preparation is the spiritual life. While we have a work to do (physically and most importantly spiritually) in getting ready for the times ahead, there is a world to warn of coming destruction! The Lord is not pleased with a self-centered program of self-preservation. I pray that we would not become so engrossed with the coming problems that we fail to give the message God has commissioned us to give. I believe that if we are about our Father's business He will see that our preparations, which are necessary, will be completed.

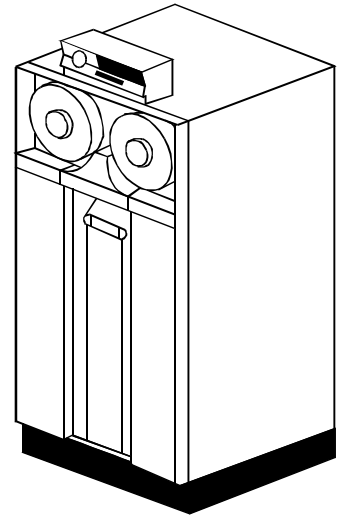

The World is waiting for January 1, 2000 to see what Y2K will bring.

While there are physical preparations that all Christians should be making for either Y2K or the time of trouble, the most important preparation is the spiritual life.

Whatever is ahead let us above all be faithful. "And the Lord said, Who then is that faithful and wise steward, whom his lord shall make ruler over his household, to give them their portion of meat in due season? Blessed is that servant, whom his lord when he cometh shall find so doing." (Luke 12:42-43)

Allen Stump

LET GOD BE TRUE!

By Etim Udo Akor

“These are the things that ye shall do; Speak ye every man the truth to his neighbour.” (Zechariah 8:16a) From this Scripture we see that the remnant have the duty of speaking the truth to his neighbor. Unfortunately, many people that claim to be Christians do not have the truth. Even churches and denominations, because they do not have the truth, speak and teach lies for doctrines among the people. This is very sad because the Scripture states: “He that worketh deceit shall not dwell within my house: he that telleth lies shall not tarry in my sight.” (Psalm 101:7)

Many churches with false messages are springing up everywhere. God’s Word assures us that these false teachers will have to answer for their wicked work. Proverbs 19:5 says, “A false witness shall not be unpunished, and he that speaketh lies shall not escape.” Jesus pities this worship and actually calls it vain! “But in vain they do worship me, teaching for doctrines the commandments of men.” (Matthew 15:9) The Bible plainly teaches that there will be many false teachings in the professed churches, especially as we near the end of time. Paul writing to Timothy said, “Now the Spirit speaketh expressly, that in the latter times some shall depart from the faith, giving heed to seducing spirits, and doctrines of devils; Speaking lies in hypocrisy; having their conscience seared with a hot iron.” (1 Timothy 4:1-2) With these warnings we should earnestly desire to let God be true in all that we believe and teach in our congregations.

Brethren, before going further let me ask, “What is the truth?” Psalm 119:142 has the answer: “Thy righteousness is an everlasting righteousness, and *thy law is the truth.*” That is speaking of the Ten Commandments of God. This law is perfect and converts the soul. (See Psalm 19:7.) Remember the duty of the remnant, or God’s last day church, is to speak the truth to his neighbor so as to bring the sinner back to God. The simple message to the sinner is, “For all have sinned, and come short of the glory of God.” (Romans 3:23) What has God designated to teach the sinner that he has transgressed against Him? It is the law, our “school master,” (Galatians 3:24) that shows us our sin for the transgression of the law is sin. (See 1 John 3:4.) To receive the grace of forgiveness into his life, a sinner must first recognize that he has transgressed

the law and then repent, confess, and forsake his sin. God has promised, “If we confess our sins, he is faithful and just to forgive us our sins, and to cleanse us from all unrighteousness.” (1 John 1:9) This process happens by faith. By faith we become children of God. (See Galatians 3:25, 26.)

Beloved, many uphold that the Ten Commandment law of God, which He spoke on Mt. Sinai (Exodus 20) and wrote with His fingers on two tables of stone (Exodus 31:18), was abolished and nailed on the cross by Jesus Christ, the Son of God. Is that true? NO, what a falsehood! Jesus said, “Think not that I am come to destroy the law, or the prophets: I am not come to destroy, but to fulfil.” (Matthew 5:17)

Some teach that the law was for the children of Israel and operational only in Old Testament times, but the Scripture says that the Old Testament was written and preserved for our learning and admonition. (See Romans 15:4.) The Apostle John wrote:

“Brethren, I write no new commandment unto you, but an old commandment which ye had from the beginning. The old commandment is the word which ye have heard from the beginning.” (1 John 2:7)

“I rejoiced greatly that I found of thy children walking in truth, as we have received a commandment from the Father. And now I beseech thee, lady, not as though I wrote a new commandment unto thee, but that which we had from the beginning, that we love one another. And this is love, that we walk after his commandments. This is the commandment, That, as ye have heard from the beginning, ye should walk in it.” (2 John 4-6)

False teachers tell the people that the law was for the Jews while grace is for the Christian, whereas the Bible says: “And hereby we do know that we know him, if we keep his commandments. He that saith, I know him, and keepeth not his commandments, is a liar, and the truth is not in him.” (1 John 2:3, 4) We cannot truly call ourselves Christians if we do not have anything to do with God’s law.

Some preachers proclaim their church to be a “New Testament Church.” In making this claim they try to disavow the Old Testament. They claim that they are teaching holiness and righteousness unto God. Let us find out what the Scriptures say about these points

they raise. Proverbs 4:2 states, “For I give you good doctrine, forsake ye not my law.” It was concerning this and other Old Testament Scriptures that the “New Testament” Peter wrote: “For the prophecy came not in old time by the will of man: but holy men of God spake as they were moved by the Holy Ghost.” (2 Peter 1:21) The law is good doctrine! 2 John 9, from the New Testament, says: “Whosoever transgresseth, and abideth not in the doctrine of Christ, hath not God. He that abideth in the doctrine of Christ, he hath both the Father and the Son.” We are to preach holiness, righteousness, and perfection because God commands us to. He tells us: “Sanctify yourselves therefore, and be ye holy: for I am the LORD your God.” (Leviticus 20:7) Jesus said, “And for their sakes I sanctify myself, that they also might be sanctified through the truth.” (John 17:19)

Yet, what is righteousness? It is the keeping of the commandments of God. Psalm 119:172 says, “My tongue shall speak of thy word: for all thy commandments are righteousness.” What righteousness are these false teachers talking about? The Bible teaches that they are teaching their own false righteousness. Romans 10:3 says, “For they being ignorant of God’s righteousness, and going about to establish their own righteousness, have not submitted themselves unto the righteousness of God.”

Now that we have seen that the law of God is the truth, what is our stand on the fourth commandment that says in part, “Remember the sabbath day, to keep it holy. Six days shalt thou labour, and do all thy work: But the seventh day is the sabbath of the LORD thy God.” (Exodus 20:8-10) Many false teachers who teach the commandments of men claim that it does not matter, but God’s holy Word says it does matter!

“The seventh day is the sabbath of the LORD thy God” and not the Sabbath of the Jews as many are taught to believe. How can anyone teach and uphold Sunday (the first day of the week) as the Lord’s day when the Bible says that the seventh day is the Lord’s day? God “worked” on the first day in creation, but He *blessed the seventh day* and sanctified it. (See Genesis 2:1-3.) Jesus said “the Sabbath was made for man” or mankind, not the Jews only. It is the day that carries the blessing. “Blessed is the man that doeth this, and the son of man that layeth hold on it; that keepeth the sabbath from polluting it, and keepeth his hand from doing any evil.” (Isaiah 56:2) “If thou turn away thy foot from the sabbath, from doing thy pleasure *on my holy day*; and call the sabbath a delight, the holy of the

LORD, honourable; and shalt honour him, not doing thine own ways, nor finding thine own pleasure, nor speaking thine own words: Then shalt thou delight thyself in the LORD; and I will cause thee to ride upon the high places of the earth, and feed thee with the heritage of Jacob thy father: for the mouth of the LORD hath spoken it.” (Isaiah 58:13, 14)

True Sabbath keeping is a sign of sanctified living. Exodus 31:13 states, “Speak thou also unto the children of Israel, saying, Verily my Sabbaths ye will keep: for it is a sign between me and you throughout your generations; that ye may know that I am the LORD that doth sanctify you.” In this Scripture the Lord says to keep His Sabbath, which is the seventh day, and not Sunday, the first day of the week. Sunday is actually the Roman Catholic Church’s Sabbath. The papacy openly acknowledges attempting to change the Sabbath from the seventh day to the first day without any Scriptural authority. If you are keeping Sunday as the Sabbath, your relationship is between you and the papacy and not between you and the God of Israel that sanctifies. In this case, you are not sanctified through the truth, but you are “sanctified” through heresies of the papacy.

The Sunday Sabbath is a tradition of men, not the accepted day of rest for the people of God. Many are arguing that if God did not approve Sunday as the day of worship there would not be the working of miracles among Sunday keepers. The Bible says that miracles are not the proof of sonship to God. In fact, the Bible says that in the last days there will be “spirits of devils, working miracles.” (Revelation 16:14) Please read carefully the words of Jesus:

“Notwithstanding in this rejoice not, that the spirits are subject unto you; but rather rejoice, because your names are written in heaven.” (Luke 10:20)

“Not every one that saith unto me, Lord, Lord, shall enter into the kingdom of heaven; but he that doeth the will of my Father which is in heaven. Many will say to me in that day, Lord, Lord, have we not prophesied in thy name? and *in thy name have cast out devils? and in thy name done many wonderful works* [miracles]? And then will I profess unto them, *I never knew you: depart from me, ye that work iniquity* [sin, which is the transgression of God’s law].” (Matthew 7:21-23)

You might wonder, “Why do the majority of people worship God on Sunday instead of Saturday, the seventh day of the week?” Many “have a zeal of God, but not according to knowledge. For they being ignorant of God’s righteousness, and going about to

establish their own righteousness, have not submitted themselves unto the righteousness of God.” (Romans 10:2, 3)

One point of argument that false teachers bring up is based on a text in Paul’s first letter to the Corinthians: “For I determined not to know any thing among you, save Jesus Christ, and him crucified.” (1 Corinthians 2:2) Do we really know and believe what this statement says? Paul did not fail to teach “all the counsel of God,” (Acts 20:27) but it was *all*—including God’s commandments as revealed through the cross of Christ! If we claim to believe Paul’s statement in First Corinthians then I ask further, “Was it Jesus the Son of God that was crucified for you or ‘God the Son,’ the second person in the Godhead according to the Trinity doctrine?”

The Bible says that “God so loved the world, that he gave his only begotten Son, that whosoever believeth in him should not perish, but have everlasting life.” (John 3:16) Jesus is the Son of God. He is never, in all the Bible, called “God the Son” as most are taught to believe according to the doctrine of the Trinity—one of the heresies of the papacy. The Trinity is in fact part of the wine (false teaching) that fills the harlot’s cup. (See Revelation 14:8; 17:2,4; 18:6.) “Whosoever shall confess that Jesus is the Son of God [not God the Son], God dwelleth in him, and he in God.” (1 John 4:15) The doctrine of the Trinity is a falsehood. The Bible does not speak of three Gods in one person—God the Father, God the Son, and God the Spirit. The Bible says that “to us there is but *one God, the Father*, of whom are all things, and we in him; and *one Lord Jesus Christ*, by whom are all things, and we by him.” (1 Corinthians 8:6) “Who is a liar but he that denieth that Jesus is the Christ? He is antichrist, that denieth the Father and the Son. Whosoever denieth the Son, the same hath not the Father: (but) he that acknowledgeth the Son hath the Father also.” (1 John 2:22, 23)

Beloved, let me conclude: “But whoso looketh into the perfect law of liberty [the ten commandments], and continueth therein, he being not a forgetful hearer, but a doer of the work, this man shall be blessed in his deed.” (James 1:25) “I have no greater joy than to hear that my children walk in truth.” (3 John 4) “But the anointing which ye have received of him abideth in you, and ye need not that any man teach you: but as the same anointing teacheth you of all things, and is truth, and is no lie, and even as it hath taught you, ye shall abide in him.” (1 John 2:27) Of course the anointing

here is for the born again believer only. So if you have not repented of your sins, please confess your sins now and repent and forsake them, for Jesus is faithful and just to forgive you and cleanse you from all unrighteousness. Let us seek after the truth, for the truth will set us free from sin. (See John 8:32.) “Blessed are they that *do his commandments*, that they may have right to the tree of life, and may enter in through the gates into the city.” (Revelation 22:14) The kingdom of God is only for the saints who have found forgiveness through Christ. “For without are dogs, and sorcerers, and whoremongers, and murderers, and idolaters, and whosoever loveth and maketh a lie.” (Revelation 22:15)

The Bible says that “to us there is but *one God, the Father*, of whom are all things, and we in him; and *one Lord Jesus Christ*, by whom are all things, and we by him.” (1 Corinthians 8:6)

Please examine whether or not the statements of faith or doctrinal beliefs of your church are in line with the Scriptures and if not change to what the Bible says. “We ought to obey God rather than man.” (Acts 5:29)

If you have confessed your sins and desire to follow Jesus in all the truth He has revealed to you, then flee Babylon and her daughters and associate yourself with an assembly that upholds the truth of the gospel according to the Scriptures. ✍

(Pastor Etim Udo Akor writes from Nigeria where he is teaching the three angels’ messages. God has blessed Brother Akor who is working under very difficult and trying circumstances. Most of the brethren in Nigeria are poor, but humble men. As Paul made an appeal for the brethren in Jerusalem (see 1 Corinthians 16), we would like to make an appeal in behalf of the work in Nigeria. For those upon whom God places a burden to help, they may write directly to Pastor Akor at his address: P. O. Box 380, Abak, Akwa Ibom State, Nigeria. Editor)

Three Days

by Pat Kroeger

He that believeth on me, as the scripture hath said, out of his belly shall flow rivers of living water. (But this spake he of the Spirit, which they that believe on him should receive: for the Holy Ghost was not yet *given*; because that Jesus was not yet glorified.) (John 7:38-39)

Although God's Spirit has always been, and has always been with man, sin had made a breach between the Spirit of God and the spirit of man. The Spirit of God is forever holy, but because of sin the human spirit had become polluted and vile. The two could not commune. The Son of God came to restore the breach by doing what man had failed to do—unfailingly submit to the Father's will.

In John 7:38 Christ is describing His followers, those who believe on Him, as having rivers of living water flowing from their bellies. Of course this is not literal for what purpose would it serve to have water literally running out from the bellies of Christians? Recognizing verse 39 as the explanation, there are three points to consider: First, the rivers of living water that Christ is speaking of is the Holy Spirit. Second, the believers had not received this Spirit as yet, but would in the future (as the early rain at Pentecost). Third, the reason was because Christ had not been glorified. Notice in verse 39 that the word "given" is in *italic*. This indicates that the word is not in the original manuscript but was supplied by the translators as their attempt to explain the text, be it right or wrong. Without the supplied this portion would read: "for the Holy Ghost was not yet; because that Jesus was not yet glorified." Without denying that the Holy Spirit has existed for as long as God the Father has existed, Christ is nonetheless stating that there was something incomplete about it. It was Christ's mission on this earth to satisfy the requirements needed to complete the missing link. Until then the early rain could not be poured out. After the resurrection Christ received assurance from His Father that His mission had been successful. The Spirit was now full and complete because humanity had been perfected with Divinity: God's Spirit was now united in fullness with the human spirit. That fullness of the Spirit could then be given back to the believers in the

early rain. With this background we want to investigate the process that it took for Jesus, the Son of God, to become perfected in Divinity. For understanding what it took to bring the outpouring of the early rain will help us understand what we need to bring the outpouring of the latter rain.

"And he began to teach them, that the Son of man must suffer many things, and be rejected of the elders, and of the chief priests, and scribes, and be killed, and after three days rise again." (Mark 8:31) The number three is significant in the Scriptures and three days, or the third day, is specifically significant since Christ referred to it several times. (See also Matthew 12:40 and John 2:19.) Each is referring to the same time period.

"And he said unto them, Go ye, and tell that fox, Behold, I cast out devils, and I do cures to day and to morrow, and the *third day I shall be perfected*." (Luke 13:32) Although Christ had never sinned He did not claim to be perfect. In fact, perfection was something that He was looking forward to in the future, on the third day. The third day from what? Christ was in the process of being perfected, but it would take Him three days to complete it. The question must be asked, "When did those three days begin?"

Hebrews 2:9-10 states: "But we see Jesus, who was made a little lower than the angels for the suffering of death, crowned with glory and honour; that he by the grace of God should taste death for every man. For it became him, for whom are all things, and by whom are all things, in bringing many sons unto glory, to make the captain of their salvation perfect through sufferings." By the grace of God Christ did achieve perfection, but that perfection came through suffering. This concept of Christ's perfection by trials and sufferings is confirmed in the following text. "Who in the days of his flesh, when he had offered up prayers and supplications *with strong crying and tears* unto

him that was able to save him from [Greek: εκ, out of] death, and was heard in that he feared; Though he were a Son, yet *learned he obedience* by the things which he suffered; And *being made perfect*, he became the author of eternal salvation unto all them that obey him.” (Hebrews 5:7-9) If Jesus, the sinless Son of God, was brought into perfection through suffering when was His greatest suffering? If He learned obedience through the things that He suffered when was His greatest lesson? When did Jesus offer up prayers and supplications with strong crying and tears? Christ’s greatest suffering was not in the tomb but facing it. It was in the Garden of Gethsemane that the final process began in overcoming sin and Self. It was in the Garden that began the three days Jesus had been looking forward to.

“And they came to a place which was named Gethsemane: and he saith to his disciples, Sit ye here, while I shall pray. And he taketh with him Peter and James and John, and began to be sore amazed [Greek: εκθαμβω, “struck with terror” *Thayer’s*], and to be very heavy [Greek: αδημονεω, “troubled, distressed” *Thayer’s*]; And saith unto them, My soul is exceeding sorrowful unto death: tarry ye here, and watch. And he went forward a little, and fell on the ground, and prayed that, if it were possible, the hour might pass from him. And he said, Abba, Father, all things are possible unto thee; take away this cup from me: nevertheless not what I will, but what thou wilt...And he cometh the third time, and saith unto them, Sleep on now, and take your rest: it is enough, the hour is come; behold, the Son of man is betrayed into the hands of sinners.” (Mark 14:32-41)

Three times Christ came to his friends for support and strength. Three times they failed Him. He must enter into this special experience without any earthly support. This added to His suffering, but it was the mental anguish that was the real source of His pain. Luke explains in a little more light just how intense was that pain and suffering. “Saying, Father, if thou be willing, remove this cup from me: nevertheless not my will, but thine, be done. And there appeared an angel unto him from heaven, strengthening him. And being in an agony he prayed more earnestly: and his sweat was as it were great drops of blood falling down to the ground. And when he rose up from prayer, and was come to his disciples, he found them sleeping for sorrow.” (Luke 22:42-45) If the angel had not come to strengthen Him Jesus would have died there in the Garden. The weight of what He was experiencing was

so severe that He sweat great drops of blood. We know from Isaiah 53 that the weight was the guilt of all our sins. He wrestled with the craving to be rid of the experience. He begged the Father to remove the cup, but instead He yielded to His Father’s will and drank it. From Gethsemane and His betrayal to His trial and agony upon the cross, when He came forth from the tomb three days later His suffering was complete and His Spirit perfected. He had made provision for our human spirit to be fully purged of carnal control. The sin-breach had been closed. Three days for Christ was a literal experience, yet Christ’s is not the only example we find of three days of trials and sufferings. In each example that the Scriptures give, there are clues as to what makes this three-day experience important.

O t h e r s W h o E x p e r i e n c e d T h r e e D a y s

The Disciples - The first obvious example is the disciples. Christ was not alone in the Garden of Gethsemane. The disciples were also just beginning their own severe trial. As they helplessly witnessed the suffering and humiliation of their beloved Master they watched their world come to an end. The bitterness and loss they endured must have been tremendous! It certainly was cleansing for not many days after they were the recipients of the outpouring of the Spirit at Pentecost.

Abraham - When God tested Abraham by asking him to sacrifice his only-begotten son Isaac Abraham obeyed without question. During the three-day journey it took to reach Mt. Moriah Abraham alone bore the pain of what he was about to do. (See Genesis. 22:1-14.) Isaac was the child of promise, the most precious gift that Abraham could hold. He would rather lose everything than to lose his precious Isaac, but Abraham had explicit faith in God and trusted Him to still keep His promise that through Isaac all nations would be blessed. (See Hebrews 11:17-19.) In this story is portrayed the depths of divine love for the experience of Abraham and Isaac symbolizes God the Father in freely giving His only-begotten Son as the Sacrifice for all mankind. The pain of heart that the Father must have suffered knowing that someday His most precious Son would willingly submit Himself to a rebellious race is something we will never fully understand.

Jonah - “Now the LORD had prepared a great fish to swallow up Jonah. And Jonah was in the belly of the

fish three days and three nights.” (Jonah 1:17) Most everyone knows the story of Jonah. Here was a messenger of God that didn’t care for the assignment he had been given. Jonah had a problem; he hadn’t truly been converted. Like many of us, God knew it would take a hard trial to bring Jonah to the experience he needed. During those three days in the belly of the whale Jonah came to understand his sin problem and God’s infinite power to forgive. From the depths of his trial he prayed his most fervent prayer. (See Jonah 2.) That was a type of Gethsemane for Jonah. The earnest prayer of confession, repentance, and surrender were a part of the three days Jonah had to experience to be purged of his sin.

Joseph and Mary - For Joseph and Mary, it was frantically searching for the Son of God. It took them three days to learn how serious it is to lose sight of the Savior. (See Luke 2:46.)

The Children of Israel - “And Moses stretched forth his hand toward heaven; and there was a thick darkness in all the land of Egypt three days: They saw not one another, neither rose any from his place for three days: but all the children of Israel had light in their dwellings.” (Exodus 10:22-23) “God is no respecter of persons” (Acts 10:34): the wicked and righteous both experience three days. During that time a contrast is seen. The children of God are brought to the light while the children of the world are brought into complete and perfect darkness.

Pharaoh’s Butler and Baker - “And Joseph said unto him, This is the interpretation of it: The three branches are three days: Yet within three days shall Pharaoh lift up thine head, and restore thee unto thy place: and thou shalt deliver Pharaoh’s cup into his hand, after the former manner when thou wast his butler.” (Genesis 40:12-13) “And Joseph answered and said, This is the interpretation thereof: The three baskets are three days: Yet within three days shall Pharaoh lift up thy head from off thee, and shall hang thee on a tree; and the birds shall eat thy flesh from off thee.” (Genesis 40:18-19) Three days is a make or break situation. Those who overcome, after they are tried, will be restored to their original position and treated as though they had never sinned. The unrepentant will be found worthy of death.

Esther - Fasting is also associated with three days. After fasting Esther was willing to die to self rather than fail at the work God had given her to do. (See Esther 4:16.)

The 5,000 - When Christ fed the five thousand it was after they had followed Him for three days, fasting on physical food while feasting on spiritual food. (See Matthew 15:32.)

Paul - After a soul-shaking experience on the road to Damascus Saul fasted for three days while he waited for direction and a sign of acceptance from the Lord. (Acts 9:9) We know from Isaiah 58 that fasting is a means God has provided to loose us from the power of sin.

We Must Experience Three Days to Perfection

“...And Jesus said unto them, Ye shall indeed drink of the cup that I drink of; and with the baptism that I am baptized withal shall ye be baptized:” (Mark 10:39) In the Garden of Gethsemane Christ spoke of a cup. Also, after His immersion in the River Jordan, Jesus stated he had to experience a baptism that it pained Him to have accomplished. (Luke 12:50 margin) The baptism and cup are both synonymous with the three days of suffering. According to the word of Christ we also will drink of the same cup and be baptized with the same baptism. For us however, three days is not a literal time but is symbolic of the time necessary for God to bring us into perfection in His Spirit. During this time we must learn absolute trust in God to bring us through or we will be lost.

“Come, and let us return unto the LORD: for he hath torn, and he will heal us; he hath smitten, and he will bind us up. After two days will he revive us: in the third day he will raise us up, and we shall live in his sight. Then shall we know, if we follow on to know the LORD: his going forth is prepared as the morning; and he shall come unto us as the rain, as the latter and former rain unto the earth.” (Hosea 6:1-3) Each example of three days in the Scriptures is associated with soul-searching, life-changing trials and events. We must experience our own three days from Gethsemane to death to self to become perfected and receive the latter rain.

“For in the hand of the LORD there is a cup, and the wine is red; it is *full of mixture*; and he poureth out of the same: but the dregs thereof, all the wicked of the earth shall wring them out, and drink them.” (Psalms 75:8) Christ drank from it and so will we, but what exactly is this cup that God holds and what is it mixed with? “Thus saith thy Lord the LORD, and thy God that pleadeth the cause of his people, Behold, I have taken out of thine hand the cup of trembling, even the

dregs of the cup of my fury; thou shalt no more drink it again.” (Isaiah 51:22) Concerning the wicked we read: “The same shall drink of the wine of the wrath of God, which is poured out *without mixture* into the cup of his indignation; and he shall be tormented with fire and brimstone in the presence of the holy angels, and in the presence of the Lamb.” (Revelation 14:10) There is fury in the cup that God holds. It begins full of mixture but ends up without mixture. The people of God must experience God’s wrath against sin in order to come to hate sin with the same hatred God has (Zechariah 12:10), but they endure God’s wrath mixed with mercy. The wicked, who have never come to hate sin but love it more than God, will experience the fullness of the wrath of God without mercy. The prophet Isaiah wrote: “Awake, awake, stand up, O Jerusalem, which hast drunk at the hand of the LORD the cup of his fury; thou hast drunken the dregs of the cup of trembling, and wrung them out.” (Isaiah 51:17) A certain class of God’s people will have to drink deeper from this cup of fury. It’s important however to remember that our suffering will never compare to what Christ experienced in Gethsemane. Because Christ was made “sin for us” (2 Corinthians 5:21), He experienced the fullness of the Father’s wrath the same way the wicked must. Yet if Christ had that experience why must we drink from this terrible cup?

Why we Must Drink the Cup?

“I will bear the indignation of the LORD, *because I have sinned against him*, until he plead my cause, and execute judgment for me: he will bring me forth to the light, and I shall behold his righteousness.” (Micah 7:9) It is because of the sin within us that we must be purged through this cup of indignation and suffering. God the Father, in His infinite wisdom, knows that nothing short of this experience will accomplish His desire. If we endure we will be brought into the righteousness of Christ.

Isaiah 10:16-19 states, “Therefore shall the Lord, the Lord of hosts, send among his fat ones leanness; and under his glory he shall kindle a burning like the burning of a fire. And the light of Israel shall be for a fire, and his Holy One for a flame: and it shall burn and devour his thorns and his briars in one day; And shall consume the glory of his forest, and of his fruitful field, both soul and body: and they shall be as when a standardbearer fainteth. And the rest [remnant] of the trees of his forest shall be few, that a *child*

may write them.” God’s indignation will purge and sift all who claim to be called by His name. This purification process will be so intense that many will not make it. Those that are left will be so few that even a child could count them. “As it was in the days of Noah.” (Luke 17:26)

“For a small moment have I forsaken thee; but with great mercies will I gather thee. In a little wrath I hid my face from thee for a moment; but with everlasting kindness will I have mercy on thee, saith the LORD thy Redeemer. For this is as the waters of Noah unto me: for as I have sworn that the waters of Noah should no more go over the earth; so have I sworn that I would not be wroth with thee, nor rebuke thee...saith the LORD that hath mercy on thee.” (Isaiah 54:7-10) There is something important about the floodwaters of Noah that God would compare it to the purification the remnant people must endure. “By faith Noah, being warned of God of things not seen as yet, moved with fear, prepared an ark to the saving of his house; by the which he condemned the world, and became heir of the righteousness which is by faith.” (Hebrews 11:7) It was by faith that Noah acted upon the will of God. When that happened, three things were accomplished: 1) His house was saved. 2) The world was condemned. 3) He became an heir of righteousness by faith. Peter says concerning that experience: “Which sometime were disobedient, when once the longsuffering of God waited in the days of Noah, while the ark was a preparing, wherein few, that is, eight souls were *saved by water.*” (1 Peter 3:20) “For I will pour water upon him that is thirsty, and floods upon the dry ground: I will pour my spirit upon thy seed, and my blessing upon thine offspring:” (Isaiah 44:3)

It’s important to remember that our suffering will never compare to what Christ experienced in Gethsemane.

The water represents God’s Spirit. Just as the waters of the flood represented salvation to the few inside the ark who accepted it, they represented divine vengeance to the many outside the ark who rejected it. So it is with the Spirit of God. The Spirit of God can save us in our hour of trial, or God’s Spirit can be the means to bring our destruction. Like Noah, the preparations we make now will determine if we find ourselves inside or outside the ark when the flood comes. The

flood is in the cup and we will either endure it mixed with mercy by faith in an Almighty God or we will have to bear alone the full measure of the wrath of God. We will drink of the cup one way or the other.

How Do We Approach the Cup?

“And the Lord said, Simon, Simon, behold Satan hath desired to have you, that he may sift you as wheat: But I have prayed for thee, that thy faith fail not: and when thou art converted, strengthen thy brethren.” (Luke 22:31-32) Peter and the other disciples also began three days in the Garden of Gethsemane. As a make or break situation, it made eleven—it broke one. During that time of trial however, there was no assurance of the outcome for anyone. Peter struggled through this time. In the garden he slept when he should have been watching and praying. At the trial he blatantly cursed and denied even knowing Christ. Despondent and discouraged when rumors of Christ’s resurrection were spreading; Peter didn’t believe. It was not until after it was over and he walked and talked with the Savior again that Peter’s conversion was complete. Judas never made it that far.

“For unto you it is given in the behalf of Christ, not only to believe on him, but also to suffer for his sake;” (Philippians 1:29) “And if children, then heirs; heirs of God, and joint-heirs with Christ; if so be that we suffer with him, that we may be also glorified together.” (Romans 8:17) We must face Gethsemane the way Christ faced it if we are to be victorious the way Christ was victorious. “Beloved, think it not strange concerning the fiery trial which is to try you, as though some strange thing happened unto you: But rejoice, inasmuch as ye are partakers of Christ’s sufferings; that, when his glory shall be revealed, ye may be glad also with exceeding joy.” (1 Peter 4:12, 13) If we are to obtain the glory of God we will have to be purified of the corruption that binds us to Satan. The humility of suffering is the method designed by God to accomplish this work. When we face the problems of this life that we all must encounter daily our reaction to these trials, however severe, should be absolute trust in our heavenly Father. Thus we should have joy, knowing that our God loves us enough to do whatever it takes to bring us into full surrender to Him.

“My brethren, count it all joy when ye fall into divers temptations; Knowing this, that the trying of your faith worketh patience. But let patience have her

perfect work, that ye may be perfect and entire, wanting nothing.” (James 1:2-4) “Blessed is the man that endureth temptation: for when he is tried, he shall receive the crown of life, which the Lord hath promised to them that love him.” (James 1:12) *Trials, hardships, and temptations come in all shapes and sizes, yet not a single one is by chance.* Each is designed by the hand of God to bring cleansing to our souls. Each is carefully weighed and balanced to meet our ability. (See 1 Corinthians 10:13.) Whatever the circumstance we should bear with patience the chastisement of God. Clinging to His promises we can rest assured that with each and every trial God will provide a way of escape. Failing to search out Christ by fasting and praying, confessing and surrendering, will deny God’s way of escape for us and will certainly bring on our destruction. Unconditional dependence on God through Christ is our only remedy. This will either make or break us; we will either be a Peter or a Judas; the Pharaoh’s cup bearer or baker. If we fail today, we will have to drink of this cup again and again until either we are victorious and pass over into the Promised Land, or we are swept away by the flood of fury coming to the children of disobedience. The choice is ours. ✍

(Pat Kroeger writes from her home in Kentucky. You may write Pat at: 7616 E Manslick Rd., Louisville, KY 40288. E-mail: isha@bullitt.net.)

In the matchless gift of His Son, God has encircled the whole world with an atmosphere of grace as real as the air which circulates around the globe. All who choose to breathe this life-giving atmosphere will live and grow up to the stature of men and women in Christ Jesus. (Ellen G. White, Steps to Christ, p. 68)

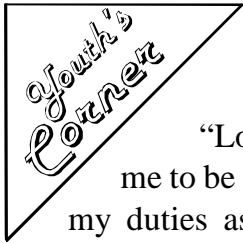

“Lord, please help me to be able to carry on my duties as a soldier and still not violate your sacred commandments,” the young Spaniard prayed as he knelt beside his army cot.

“Please help me to have the words and earnestness that’ll cause my captain to release me from military exercises on Your holy day. In Christ’s name, Amen.”

Rising to his feet, he walked over to the one folding chair in the tent, sat down, and began a letter to one of his friends in his church back home. “I want you to ask the other people in the church to pray for me that when I approach the captain about being released from duty on the Lord’s holy day, he will be touched by the Holy Spirit. He’s a good man, but I don’t know if he is a Christian or not. I cannot violate my conscience and I don’t believe he’s the kind of a guy who would force someone to do so. But this is war and war makes people think very strangely sometimes. So, please . . .”

Before he could finish the letter, a sudden inspection was called. When he went outside to fall into line with the rest of the young men in his outfit, the wind was blowing. His hair would not stay in place. So, he pulled his hat down tightly on his head, hoping that it would keep it in place long enough to pass inspection.

In Advance

Everyone gave a sigh of relief when they had passed inspection.

“I thought the wind would really mess me up,” he told a fellow soldier. “I just knew it meant trouble when I stepped out of my tent and saw all the dust flying.”

“Come on over to the base exchange with me,” his friend said, “and let’s get something cold to drink. We’ve gotta wash down all this dust.”

As he and his friend were walking back to his tent after getting a cold drink, he was halted by a familiar voice. It was his captain’s.

“Come into my tent,” the officer commanded him, “I want to talk to you.”

As they sat down on padded folding chairs in the captain’s tent, he was surprised by his commanding officer’s words. “I want you to tell me all about what you believe as a Christian.”

The captain listened intently as he tried to tell him all of his beliefs. It was difficult, but the officer seemed to recognize his nervousness. The captain finally stood to his feet and said, “I wanted you to come in and talk for a few minutes before I tell you of my decision.”

“Your decision, Sir?” the bewildered Christian young man asked.

“Yes,” he replied, “I had to make a decision about whether or not to let you off from duty on the Christian’s day of rest.” This almost shocked the soldier right off

his chair. He just could not believe his own ears. He had not even asked the captain for exemption yet. Then the next official statement was even more surprising.

“I’ve decided to grant you leave from your military duties on your day of rest.”

Stunned beyond belief, he rose to his feet, thanked, and saluted him. Then he attempted to walk out of the tent without showing that he could hardly stand up. But, before he pushed back the door flap of the tent, a holy boldness that comes to Christ’s own came to him.

“Sir, may I ask you how you came to this decision?”

“Sure,” the captain smiled for the first time that the soldier had ever seen or heard of. “I read the letter you started to your buddy back home, where you asked him to ask the members of your church to pray that your captain wouldn’t ask you to violate your conscience. The wind must have blown it right into my tent.” ✍

(This story was reprinted from the book, *The Hand That Still Intervenes*, W. A. Spicer and Helen Spicer Menkel © 1982 by Concerned Publications. Permission to reprint this article was graciously granted by the publishers.)

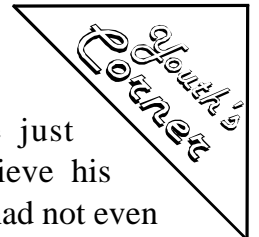

Hearth to Hearth

A Stirring Personal Testimony

We live in a world of specialization. Perhaps that truth is most evident in the field of publishing. There are magazines that cover topics ranging from bow-hunting to coin collecting. One area of specialization that we are very pleased to recommend is a new publication entitled, *Hearth to Hearth*.

Hearth to Hearth is a bi-monthly publication designed especially for Christian women. The publishers, Grace Cox and Esther McDaniel, have personally experienced isolation at times from close friendships with other Christian women and wanted



to open the door for like-minded women to be able to communicate with each other about their special concerns and issues. They are hoping, through this publication, to encourage the reader's spiritual growth into completeness in Christ.

The mission statement of *Hearth to Hearth* reads as follows: "Believing that we can find completeness in all areas of our lives only 'in him, who is the head of all principality and power' (Colossians 2:10), it is the mission of *Hearth to Hearth* to provide a forum for Christian women to reach out to each other in friendship, with joy and hope, and to encourage each other to find our completeness in Christ as we sojourn here on our way to the kingdom."

Though written by women for women, we have found the material in this paper to be a blessing to any who are interested in spiritual things. Believing this newsletter to be such a blessing, we at Smyrna have included the recent release of *Hearth to Hearth* with this issue of *Old Paths* for your consideration. *Hearth to Hearth* is sent free upon request. Voluntary donations toward the costs of printing and mailing are appreciated. To receive *Hearth to Hearth* you may submit your request to: Grace Cox, 68 Skiff Barton Rd., Trenton, TN 38382 (901) 855-4805, hearth@iswt.com.

Editors

I would like to share with you a recent experience that means a lot to me. My husband makes no profession of religion. Though he does believe in God, he has not been convinced of the divinity of Christ. He was particularly interested in learning what the Bible has to say regarding the Holy Spirit, and decided to undertake his own independent study, using only the King James Version Bible and a concordance. He believes in taking the Bible as it reads, without superimposing any preconceived ideas over the statements of scripture. This is the way he approached his study of the Holy Spirit.

By the end of the first day of his study, he was showing me from Scripture that the Holy Spirit could not be a being separate from God and His Son. He had found too many plain statements that, to his unbiased thinking, could only mean that the Spirit is the divine essence of the life of God and Christ; that the Son received it from, and shares it with, His Father and in turn imparts it to us. In the process of his study, he wrote down many texts; two that especially spoke to him were John 20:22 and John 7:39 which say, "And when he had said this, he breathed on them, and saith unto them, Receive ye the Holy Ghost: ... But this spake he of the Spirit, which they that believe on him should receive: for the Holy Ghost was not yet given; because that Jesus was not yet glorified."

In addition, his study led him to the inevitable conclusion that Jesus Christ was Who He said He was: the divine, only begotten Son of God! Praise the Lord for the sufficiency of His Word!

Name Withheld

Correction: Last month we listed Bob Talios' address incorrectly. It should have read: 5259 NW 52ND CT, Chiefland, Florida 32626. We apologize for any inconvenience experienced.

Old Paths is published monthly by Smyrna Gospel Ministries, HC 64 Box 128-B, Welch, WV 24801-9606. It is sent free upon request. E-mail address - Stump: editor@smyrna.org; Beachy: berean@smyrna.org. Phone: (304) 732-9204; Our web site URL is: http://www.smyrna.org.

Editor Allen Stump
Associate Editor Lynnford Beachy